

Superposition Examples

The following examples illustrate the proper use of superposition of dependent sources. All superposition equations are written by inspection using voltage division, current division, series-parallel combinations, and Ohm's law. In each case, it is simpler not to use superposition if the dependent sources remain active.

Example 1

The object is to solve for the current i in the circuit of Fig. 1. By superposition, one can write

$$i = \frac{24}{3+2} - 7\frac{2}{3+2} - \frac{3i}{3+2} = 2 - \frac{3}{5}i$$

Solution for i yields

$$i = \frac{2}{1+3/5} = \frac{5}{4} \text{ A}$$

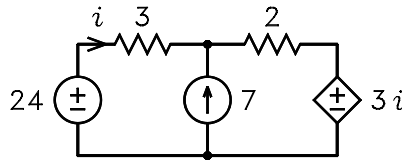

Figure 1: Circuit for example 1.

If superposition of the controlled source is not used, two solutions must be found. Let $i = i_a + i_b$, where i_a is the current with the 7 A source zeroed and i_b is the current with the 24 V source zeroed. By superposition, we can write

$$i_a = \frac{24}{3+2} - \frac{3i_a}{3+2} \quad i_b = -7\frac{2}{3+2} - \frac{3i_b}{3+2}$$

Solution for i_a and i_b yields

$$i_a = \frac{\frac{24}{3+2}}{1 + \frac{3}{3+2}} = 3 \text{ A} \quad i_b = \frac{-7\frac{2}{3+2}}{1 + \frac{3}{3+2}} = -\frac{7}{4} \text{ A}$$

The solution for i is thus

$$i = i_a + i_b = \frac{5}{4} \text{ A}$$

This is the same answer obtained by using superposition of the controlled source.

Example 2

The object is to solve for the voltages v_1 and v_2 across the current sources in Fig. 2, where the datum node is the lower branch. By superposition, the current i is given by

$$i = 2\frac{7}{7+15+5} + \frac{3}{7+15+5} + 4i\frac{7+15}{7+15+5} = \frac{17}{27} + \frac{88}{27}i$$

Solution for i yields

$$i = \frac{17/27}{1 - 88/27} = -\frac{17}{61} \text{ A}$$

Although superposition can be used to solve for v_1 and v_2 , it is simpler to write

$$v_2 = 5i = -1.393 \text{ V} \quad v_1 = v_2 - (4i - i)15 = 11.148 \text{ V}$$

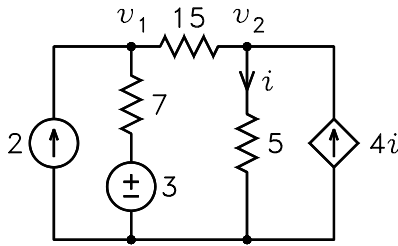

Figure 2: Circuit for example 2.

Example 3

The object is to solve for the current i_1 in the circuit of Fig. 3. By superposition, one can write

$$i_1 = \frac{30}{6+4+2} + 3\frac{4}{6+4+2} - 8i_1\frac{6}{6+4+2} = \frac{42}{12} - 4i_1$$

Solution for i_1 yields

$$i_1 = \frac{42/12}{1+4} = 0.7 \text{ A}$$

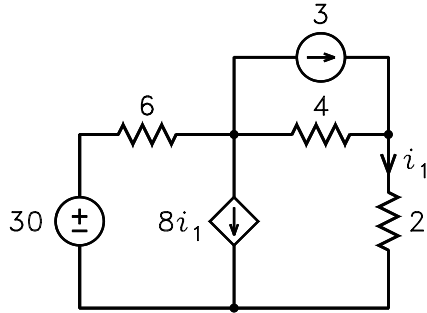

Figure 3: Circuit for example 3.

Example 4

The object is to solve for the Thévenin equivalent circuit seen looking into the terminals $A - A'$ in the circuit of Fig. 4. By superposition, the voltage v_x is given by

$$v_x = (3 - i_o)(2 \parallel 40) + 5v_x\frac{2}{40+2} = \frac{80}{42}(3 - i_o) + \frac{10}{42}v_x$$

where i_o is the current drawn by any external load and the symbol “ \parallel ” denotes a parallel combination. Solution for v_x yields

$$v_x = \frac{80/42}{1 - 10/42}(3 - i_o) = 2.5(3 - i_o)$$

Although superposition can be used to solve for v_o , it is simpler to write

$$v_o = v_x - 5v_x = -30 + 10i_o$$

It follows that the Thévenin equivalent circuit consists of a -30 V source in series with a -10Ω resistor. The circuit is shown in Fig. 5.

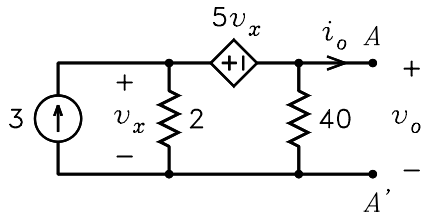

Figure 4: Circuit for example 4.

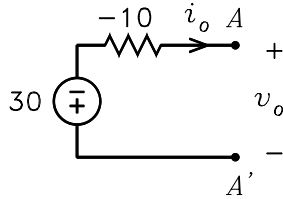

Figure 5: Thévenin equivalent circuit.

Example 5

The object is to solve for the voltage v_o in the circuit of Fig. 6. By superposition, the current i_b is given by

$$\begin{aligned}
 i_b &= \frac{70}{4 \parallel 20 + 2 \parallel 10} \frac{20}{4 + 20} + \frac{50}{10 + 4 \parallel 20 \parallel 2} \frac{20 \parallel 2}{4 + 20 \parallel 2} \\
 &\quad - \frac{2i_b}{20 \parallel 2 + 4 \parallel 10} \frac{10}{4 + 10} \\
 &= \frac{35}{3} + \frac{25}{18} - \frac{11}{36} i_b
 \end{aligned}$$

Solution for i_b yields

$$i_b = \frac{35/3 + 25/18}{1 + 11/36} = 10 \text{ A}$$

Although superposition can be used to solve for v_o , it is simpler to write

$$v_o = 70 - 4i_b = 30 \text{ V}$$

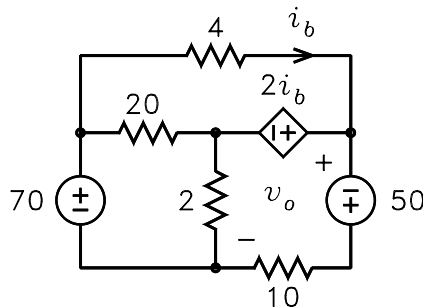

Figure 6: Circuit for example 5.

Example 6

The object is to solve for the voltage v_o in the circuit of Fig. 7. By superposition, the voltage v_Δ is given by

$$v_\Delta = -0.4v_\Delta \times 10 + 5 \times 10$$

This can be solved for v_Δ to obtain

$$v_\Delta = \frac{5 \times 10}{1 + 0.4 \times 10} = 10 \text{ V}$$

By superposition, i_Δ is given by

$$i_\Delta = \frac{10}{5 + 20} - 0.4v_\Delta \frac{20}{20 + 5} = \frac{10}{25} - 0.4v_\Delta \frac{20}{25} = -\frac{70}{25} \text{ A}$$

Thus v_o is given by

$$v_o = 10 - 5i_\Delta = 24 \text{ V}$$

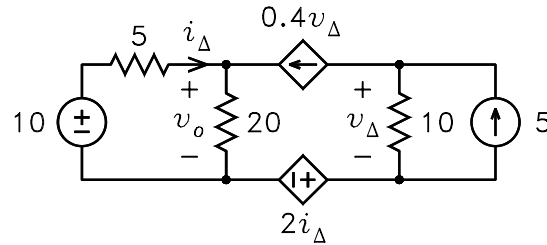

Figure 7: Circuit for example 6.

Example 7

The object is to solve for the voltage v as a function of v_s and i_s in the circuit in Fig. 8. By superposition, the current i is given by

$$i = \frac{v_s}{5} - \frac{2}{5}i_s - \frac{3}{5} \times 3i$$

This can be solved for i to obtain

$$i = \frac{v_s}{14} - \frac{i_s}{7}$$

By superposition, the voltage v is given by

$$\begin{aligned} v &= \frac{v_s}{5} - \frac{2}{5}i_s + \frac{2}{5} \times 3i \\ &= \frac{v_s}{5} - \frac{2}{5}i_s + \frac{2}{5} \times 3 \left(\frac{v_s}{14} - \frac{i_s}{7} \right) \\ &= \frac{2}{7}v_s - \frac{4}{7}i_s \end{aligned}$$

Example 8

This example illustrates the use of superposition in solving for the dc bias currents in a BJT. The object is to solve for the collector current I_C in the circuit of Fig. 9. Although no explicit dependent sources are shown, the three BJT currents are related by $I_C = \beta I_B = \alpha I_E$, where β is the current gain and $\alpha = \beta / (1 + \beta)$. If any one of the currents is zero, the other two must also be zero. However, the currents can be treated as independent variables in using superposition.

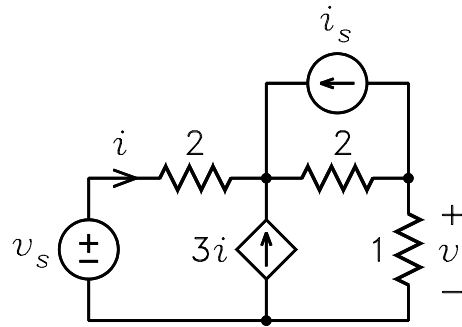

Figure 8: Circuit for Example 7.

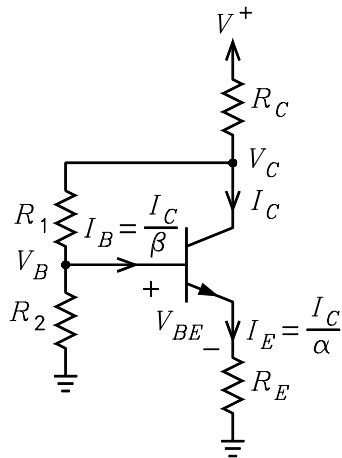

Figure 9: Circuit for example 8.

By superposition of V^+ , $I_B = I_C/\beta$, and I_C , the voltage V_B is given by

$$V_B = V^+ \frac{R_2}{R_C + R_1 + R_2} - \frac{I_C}{\beta} [(R_C + R_1) \parallel R_2] - I_C \frac{R_C R_2}{R_C + R_1 + R_2}$$

A node-voltage solution for V_B requires the solution of two simultaneous equations to obtain the same answer which superposition yields by inspection. This equation and the equation

$$V_B = V_{BE} + \frac{I_C}{\alpha} R_E$$

can be solved for I_C to obtain

$$I_C = \frac{V^+ \frac{R_2}{R_C + R_1 + R_2} - V_{BE}}{\frac{(R_C + R_1) \parallel R_2}{\beta} + \frac{R_C R_2}{R_C + R_1 + R_2} + \frac{R_E}{\alpha}}$$

In most contemporary electronics texts, the value $V_{BE} = 0.7 \text{ V}$ is assumed in BJT bias calculations.

Example 9

This example illustrates the use of superposition to solve for the small-signal base input resistance of a BJT. Fig. 10 shows the small-signal BJT hybrid-pi model with a resistor R_E from emitter to ground and a resistor R_C from collector to ground. In the model, $r_\pi = V_T/I_B$ and $r_0 = (V_A + V_{CE})/I_C$, where V_T is the thermal voltage, I_B is the dc base current, V_A is the Early voltage, V_{CE} is the dc collector-emitter voltage, and I_C is the dc collector current.

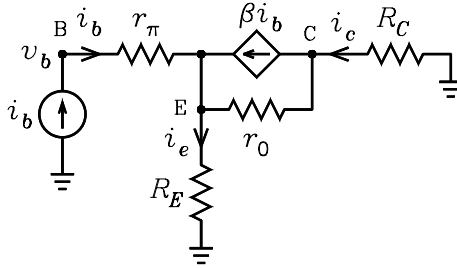

Figure 10: Circuit for example 9.

By superposition of i_b and βi_b , the base voltage v_b is given by

$$v_b = i_b [r_\pi + R_E \parallel (r_0 + R_C)] + \beta i_b \frac{r_0}{R_E + r_0 + R_C} R_E$$

This can be solved for the base input resistance $r_{ib} = v_b/i_b$ to obtain

$$r_{ib} = r_\pi + R_E \parallel (r_0 + R_C) + \frac{\beta r_0 R_E}{R_E + r_0 + R_C}$$

which simplifies to

$$r_{ib} = r_\pi + R_E \frac{(1 + \beta) r_0 + R_C}{R_E + r_0 + R_C}$$

A node-voltage solution for r_{ib} requires the solution of three simultaneous equations to obtain the same answer which follows almost trivially by superposition.

Example 10

This example illustrates the use of superposition with an op-amp circuit. The circuit is shown in Fig. 11. The object is to solve for v_O . With $v_2 = 0$, it follows that $v_A = v_1$, $v_B = 0$, and $v_C = [1 + R_4/(R_3 \parallel R_5)] v_1$. By superposition of v_A and v_C , v_O can be written

$$v_O = -\frac{R_2}{R_5}v_A - \frac{R_2}{R_1}v_C = -\left[\frac{R_2}{R_5} + \frac{R_2}{R_1}\left(1 + \frac{R_4}{R_3 \parallel R_5}\right)\right]v_1$$

With $v_1 = 0$, it follows that $v_A = 0$, $v_B = v_2$, and $v_C = -(R_4/R_5)v_2$. By superposition of v_2 and v_C , v_O can be written

$$\begin{aligned} v_O &= \left(1 + \frac{R_2}{R_1 \parallel R_5}\right)v_2 - \frac{R_2}{R_1}v_C \\ &= \left(1 + \frac{R_2}{R_1 \parallel R_5} + \frac{R_2 R_4}{R_1 R_5}\right)v_2 \end{aligned}$$

Thus the total expression for v_O is

$$\begin{aligned} v_O &= -\left[\frac{R_2}{R_5} + \frac{R_2}{R_1}\left(1 + \frac{R_4}{R_3 \parallel R_5}\right)\right]v_1 \\ &\quad + \left(1 + \frac{R_2}{R_1 \parallel R_5} + \frac{R_2 R_4}{R_1 R_5}\right)v_2 \end{aligned}$$

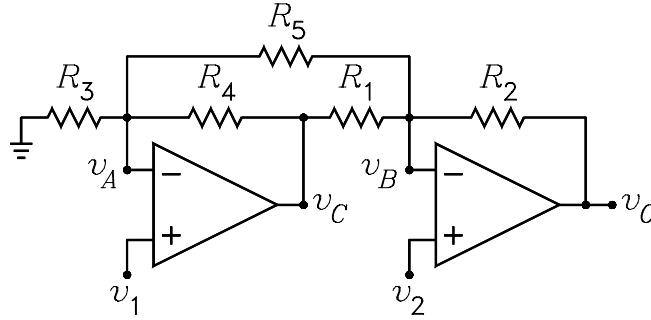

Figure 11: Circuit for Example 10.

Example 11

Figure 12 shows a circuit that might be encountered in the noise analysis of amplifiers. The amplifier is modeled by a z -parameter model. The square sources represent noise sources. V_{ts} and I_{tA} , respectively, model the thermal noise generated by Z_x and Z_A . V_n and I_n model the noise generated by the amplifier. The amplifier load is an open circuit so that $I_2 = 0$. The open-circuit output voltage is given by

$$V_{o(oc)} = z_{12}I_1 + I_A Z_A$$

By superposition, the currents I_1 and I_A are given by

$$\begin{aligned} I_1 &= \frac{V_s + V_{ts} + V_n}{Z_S + Z_A + z_{11}} + I_n \frac{Z_S + Z_A}{Z_S + Z_A + z_{11}} \\ &\quad - I_{tA} \frac{Z_A}{Z_S + Z_A + z_{11}} \\ I_A &= \frac{V_s + V_{ts} + V_n}{Z_S + Z_A + z_{11}} - I_n \frac{z_{11}}{Z_S + Z_A + z_{11}} \\ &\quad + I_{tA} \frac{Z_S + z_{11}}{Z_S + Z_A + z_{11}} \end{aligned}$$

Note that when $I_n = 0$, the sources V_s , V_{ts} , and V_n are in series and can be considered to be one source equal to the sum of the three. When these are substituted into the equation for $V_{o(oc)}$ and the equation is simplified, we obtain

$$V_{o(oc)} = \frac{z_{21} + Z_A}{Z_S + Z_A + z_{11}} \left[V_s + V_{ts} + V_n + I_n \frac{(Z_S + Z_A) z_{21} - Z_A z_{11}}{z_{21} + Z_A} - I_{tA} \frac{Z_A z_{21} - (Z_S + z_{11}) Z_A}{z_{21} + Z_A} \right]$$

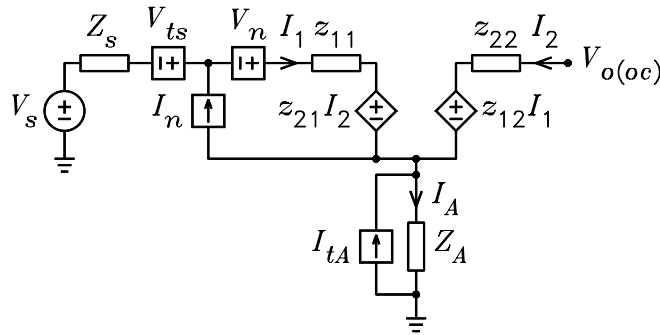

Figure 12: Circuit for Example 11.

Example 12

It is commonly believed that superposition can only be used with circuits that have more than one source. This example illustrates how it can be use with a circuit having one. Consider the first-order all-pass filter shown in Fig. 13(a). An equivalent circuit is shown in Fig. 13(b) in which superposition can be used to write by inspection

$$V_o = \left(1 + \frac{R_1}{R_1}\right) \frac{RCs}{1 + RCs} V_i - \frac{R_1}{R_1} V_i = \frac{RCs - 1}{RCs + 1} V_i$$

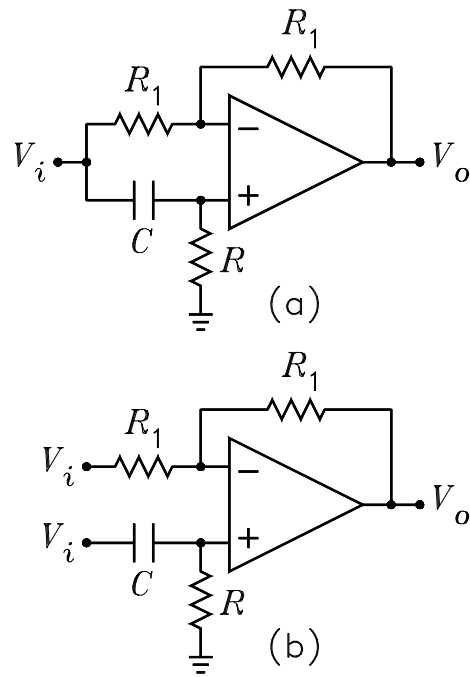

Figure 13: Circuit for Example 12.