

# 4. BIPOLAR JUNCTION TRANSISTOR (BJT) NOISE MEASUREMENTS

---

## 4.1 Object

The objective of this experiment is to measure the mean-square equivalent input noise,  $\overline{v_{ni}^2}$ , and base spreading resistance,  $r_x$ , of some NPN Bipolar Junction Transistors (BJTs).

## 4.2 Theory

### 4.2.1 Equivalent Input Noise

It can be shown that  $\overline{v_{ni}^2}$ , the mean-square equivalent input noise measured over a narrow frequency band  $\Delta f$  centered at frequency  $f$ , of a resistively loaded BJT amplifier with zero small-signal impedance from both base to ground and emitter to ground is given by

$$\overline{v_{ni}^2} = \left[ 4kTr_x + \left( 2q + \frac{K_f}{f} \right) \frac{I_C}{\beta} r_x^2 + 2qI_C \left( \frac{r_x}{\beta} + \frac{V_T}{I_C} \right)^2 \right] \Delta f \quad (4.1)$$

where,  $r_x$  is the base spreading resistance (Ohms),  $\beta = \Delta I_C / \Delta I_B$  is the small-signal current gain (dimensionless),  $I_C$  is the DC collector current (Amps),  $I_B$  is the DC base current (Amps),  $k = 1.3806568 \times 10^{-23}$  (JK<sup>-1</sup>) is Boltzmann's constant,  $T$  is the temperature in degrees Kelvin (K),  $q = 1.60217733 \times 10^{-19}$  (C) is the electronic charge or charge on an electron,  $V_T = kT/q$ , is the thermal voltage (Volts),  $K_f$  is the flicker noise-coefficient, and  $f$  is the frequency at which the mean-square noise voltage  $\overline{v_{ni}^2}$  is measured. If the noise measurement is made at a frequency  $f$  where the flicker noise may be ignored, the expression for the mean-square equivalent input noise becomes

$$\overline{v_{ni}^2} = \left[ 4kTr_x + 2q \frac{I_C}{\beta} r_x^2 + 2qI_C \left( \frac{r_x}{\beta} + \frac{V_T}{I_C} \right)^2 \right] \Delta f \quad (4.2)$$

which is not a function of  $f$ , i.e. it is white over these frequencies.

Thus Eqn.4.1 may be used to calculate the equivalent input noise of a BJT if the collector current and transistor parameters are known. The small-signal current gain  $\beta$  may be readily measured from either the output or transfer characteristics of the transistor. But attempting

to measure the base spreading resistance,  $r_x$ , from the DC characteristics is a Sisyphean task. However, it can be determined from noise measurements.

#### 4.2.2 Base Spreading Resistance

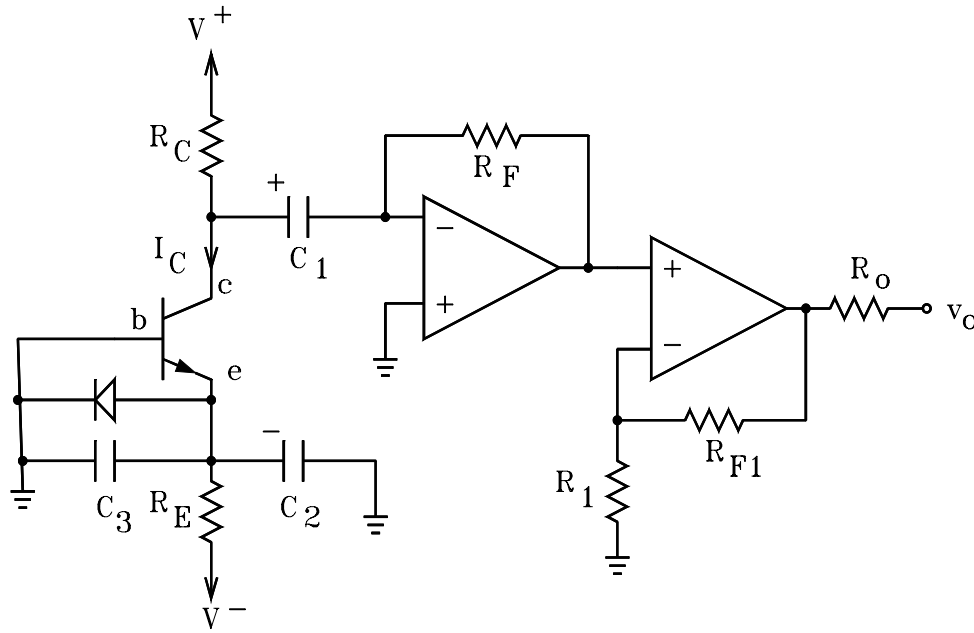

Figure 4-1 Circuit for Measuring Base Spreading Resistance

The base spreading resistance of a BJT is one of the more prickly parameters to accurately measure. It can be measured using the circuit shown in Fig.4-1. If it is assumed that the op amp is ideal and that the thermal noise in the feedback resistor,  $R_F$ , can be ignored, the mean-square output voltage of the op amp,  $\overline{v_{no}^2}$ , is given by

$$\overline{v_{no}^2} = A_1^2 R_F^2 G_m^2 \left[ 4kT r_x + \left( 2qI_b + \frac{K_f I_B}{f} \right) r_x^2 + \frac{2qI_C}{G_m^2} \right] \Delta f \quad (4.3)$$

where

$$G_m = \frac{1}{\frac{r_x}{\beta} + \frac{V_T}{I_C}} \quad (4.4)$$

and  $A_1 = 1 + R_{F1}/R_1$ . If the measurement is made at a large enough frequency so that the flicker noise component can be neglected, then the base spreading resistance satisfies the quadratic equation

$$\left[ \frac{A}{\beta^2} - \frac{2qI_C}{\beta} \Delta f \right] r_x^2 + \left[ \frac{2AV_T}{\beta I_C} - 4kT \Delta f \right] r_x + \frac{AV_T^2}{I_C^2} = 0 \quad (4.5)$$

where

$$A = \frac{\overline{v_{no}^2}}{A_1^2 R_F^2} - 2qI_C \Delta f \quad (4.6)$$

Thus Eqn.4.5 may be solved to determine  $r_x$  using the measured value of  $\overline{v_{no}^2}$ . Only the positive solution for  $r_x$  should be used since the negative value has no physical meaning. A more exact solution may be obtained by directly solving Eqn.4.3.

The capacitor  $C_1$  is a coupling capacitor which prevents DC current from the transistor from flowing into the resistor  $R_F$  while forcing the entire signal component of the collector current to flow through this feedback resistor. The op amp inverting terminal is at a virtual ground which means that the signal component of the collector voltage is zero which eliminates the Early effect. The capacitor  $C_2$  is a bypass capacitor which places the emitter at signal ground. Both of these capacitors are chosen to be large so that the low frequency noise spectra is not altered. This means that these capacitors are electrolytic and the polarity is shown.

## 4.3 Laboratory Procedure

### 4.3.1 Base Spreading Resistance

Assemble the circuit shown in Fig.4-1 on a solderless breadboard using a 2N4401 NPN BJT. Use TL071s as the op amps. Use  $V^+ = +15\text{ V}$  and  $V^- = -15\text{ V}$  (these may be reduced to 9 V if the experimenters choose to assemble the circuits in the shielded boxes). Pick  $C_1 = 10\ \mu\text{F}$  and  $C_2 = 330\ \mu\text{F}$ . The power supply decoupling network consisting of  $100\ \Omega$  resistors and  $100\ \mu\text{F}$  capacitors should be used. Insert a  $100\ \Omega$  resistor between the output node of the circuit and the lead to the oscilloscope or signal analyzer. Insert a  $100\ \text{pF}$  capacitor between the base and emitter terminals to eliminate possible RF electromagnetic interference and a 1N4148 diode to protect the base-to-emitter junction of the transistor from a possible damaging reverse voltage.

Select  $R_E = 300\ \text{k}\Omega$  and  $R_C = 270\ \text{k}\Omega$ . The collector current is given by

$$I_C = \frac{-V^- - V_{BE}}{R_E} \quad (4.7)$$

where  $V_{BE}$  may be assumed to be 0.65 V. Eqn.4.7 may be used to determine  $I_C$ . (It should be borne in mind that  $V^-$  is a negative voltage so  $-V^-$  is a positive voltage.) However, a more accurate value of the collector current can be obtained by direct measurement. Directly measure the collector current by using the DMM (Digital Multimeter) to measure the DC voltage across  $R_C$  and then use Ohm's law to determine the current. Measure the DC voltage at each terminal of the transistor.

The selection of the feedback resistor,  $R_F$ , is somewhat arbitrary. The larger  $R_F$  is the larger the output noise will be. But the larger  $R_F$  is the larger the thermal noise produced

by this resistor will be. A value of  $R_F = 100\text{ k}\Omega$  should suffice. The non inverting gain stage is picked to have a gain of 101, by selecting  $R_{F1} = 10\text{ k}\Omega$  and  $R_1 = 100\ \Omega$ .

Use the Dynamic Signal Analyzer to measure the mean-square output noise voltage,  $\overline{v_{no}^2}$ , at a frequency that is large enough so that the flicker noise may be neglected and at a low enough frequency so that the op amp and transistor combination have not begun rolling off the frequency response, i.e. make the measurement at a frequency where the output voltage is white or flat as a function of frequency.

Repeat the measurement for the 2N3904 NPN BJT.

### 4.3.2 NPN Equivalent Input Noise

The mean-square input noise,  $\overline{v_{ni}^2}$ , is related to the mean-square output noise by

$$\overline{v_{ni}^2} = \frac{\overline{v_{no}^2}}{A_1^2 G_m^2 R_F^2} \quad (4.8)$$

This expression is to be compared with Eqn.4.1 once the base spreading resistance and small-signal current gain are determined.

### 4.3.3 Transistor Parameters

Use a transistor curve tracer to measure the small-signal current gain,  $\beta$ , of the 2N4401 and 2N3904 NPN BJTs for collector current used above.

### 4.3.4 Resistance Measurement

Use the DMM (Digital Multimeter) or the LCR meter to measure the value of each resistor that was used.

### 4.3.5 Measurement Bandwidth

Record the measurement bandwidth that was used by the **HP3270A** Dynamic Signal Analyzer. Press Disp Format and then Measurement State.

## 4.4 Laboratory Report

### 4.4.1 Bias

Tabulate the quiescent bias voltages and currents for each transistor for which data was taken.

### 4.4.2 Base Spreading Resistance

From the data obtained calculate the  $r_x$  of each transistor at the three collector bias currents that were used. What is the average value of  $r_x$  for each transistor type at the three collector bias currents? Also tabulate the values of  $r_x$  for each of the transistors.

### 4.4.3 Equivalent Input Noise

Use the values of that  $r_x$  were obtained to calculate  $\overline{v_{ni}^2}$  using Eqn.4.1. Compare these results to those obtained from Eqn.4.8 and the measured values of  $\overline{v_{no}^2}$ . Explain any significant differences between these results.