

Cascode Amplifier Example - Fall 2000

$$R_p(x,y) := \frac{x \cdot y}{x + y}$$

Function for calculating parallel resistors.

$$R_1 := 390000 \quad R_2 := 200000 \quad R_3 := 56000 \quad R_4 := 100$$

$$R_C := 20000 \quad R_E := 4300 \quad R_S := 1000 \quad R_L := 10000$$

$$V_p := 65 \quad V_m := 0 \quad V_{BE} := 0.65 \quad V_T := 0.025 \quad \beta := 199 \quad \alpha := 0.995$$

$$r_x := 20 \quad r_o := 50000$$

$$v_s := 1 \quad \text{With } v_s = 1, \text{ the voltage gain is equal to } v_o.$$

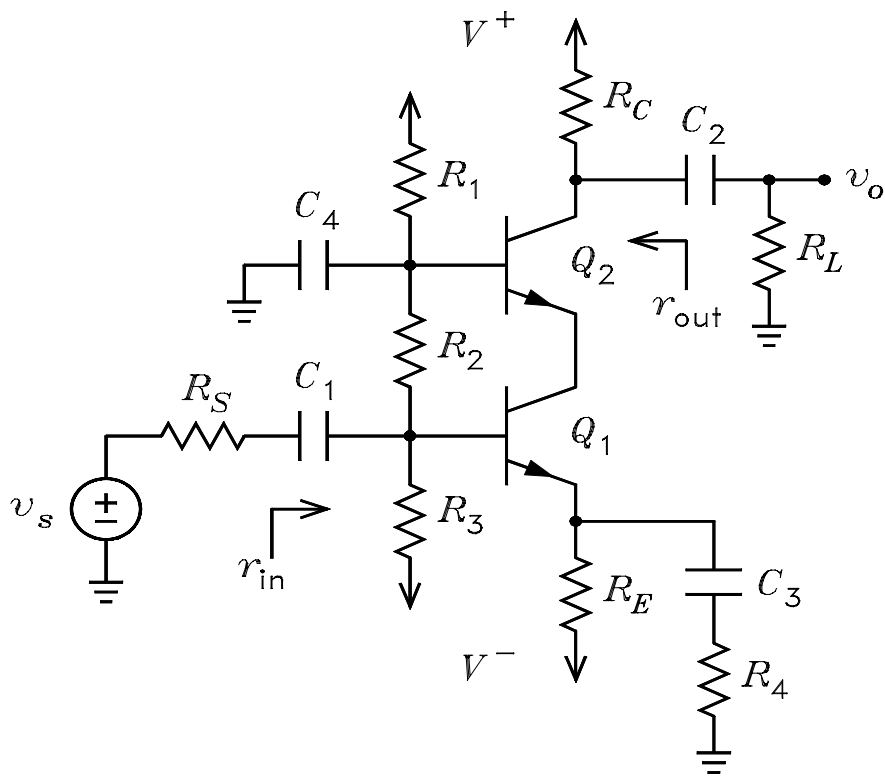

DC Bias Solution

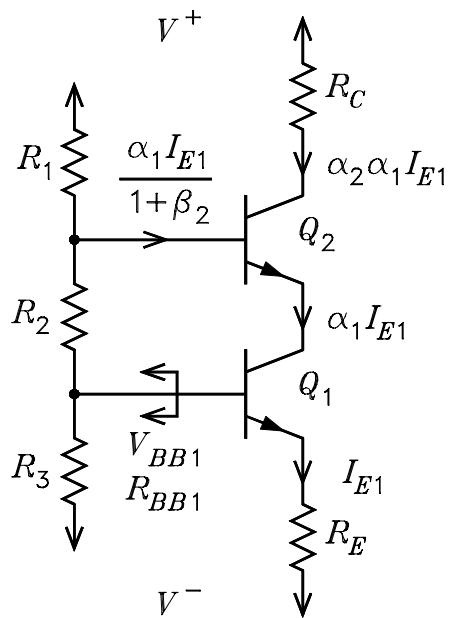

$$V_{BB1} := \frac{V_p \cdot R_3 + V_m \cdot (R_1 + R_2)}{R_1 + R_2 + R_3} - \frac{\alpha \cdot I_{E1}}{1 + \beta} \cdot \frac{R_1}{R_1 + R_2 + R_3} \cdot R_3$$

$$R_{BB1} := R_p(R_1 + R_2, R_3)$$

$$V_{BB1} - V_m := \frac{I_{E1}}{1 + \beta} R_{BB1} + V_{BE} + I_{E1} \cdot R_E$$

Solve these to obtain.

$$I_{E1} := \frac{\frac{V_p \cdot R_3 + V_m \cdot (R_1 + R_2)}{R_1 + R_2 + R_3} - V_m - V_{BE}}{\frac{R_{BB1}}{1 + \beta} + R_E + \frac{\alpha}{1 + \beta} \cdot \frac{R_1 \cdot R_3}{R_1 + R_2 + R_3}} \quad I_{E1} = 1.0552 \cdot 10^{-3}$$

$$r_{e1} := \frac{V_T}{I_{E1}} \quad r_{e1} = 23.6922$$

$$I_{E2} := \alpha \cdot I_{E1} \quad I_{E2} = 1.0499 \cdot 10^{-3}$$

$$r_{e2} := \frac{V_T}{I_{E2}} \quad r_{e2} = 23.8113$$

Checks for active mode.

$$V_{B1} := V_{BE} + I_{E1} \cdot R_E + V_m \quad V_{B1} = 5.1874$$

$$V_{B2} := \frac{V_p \cdot (R_2 + R_3) + V_m \cdot R_1}{R_1 + R_2 + R_3} - \frac{I_{E2}}{1 + \beta} \cdot R_p(R_1, R_2 + R_3) \quad V_{B2} = 24.9472$$

$$V_{C1} := V_{B2} - V_{BE} \quad V_{C1} = 24.2972$$

$$V_{CB1} := V_{C1} - V_{B1} \quad V_{CB1} = 19.1098 \quad \text{Active mode.}$$

$$V_{C2} := V_p - \alpha \cdot I_{E2} \cdot R_C \quad V_{C2} = 44.1065$$

$$V_{CB2} := V_{C2} - V_{B2} \quad V_{CB2} = 19.1594 \quad \text{Active mode.}$$

AC Solution

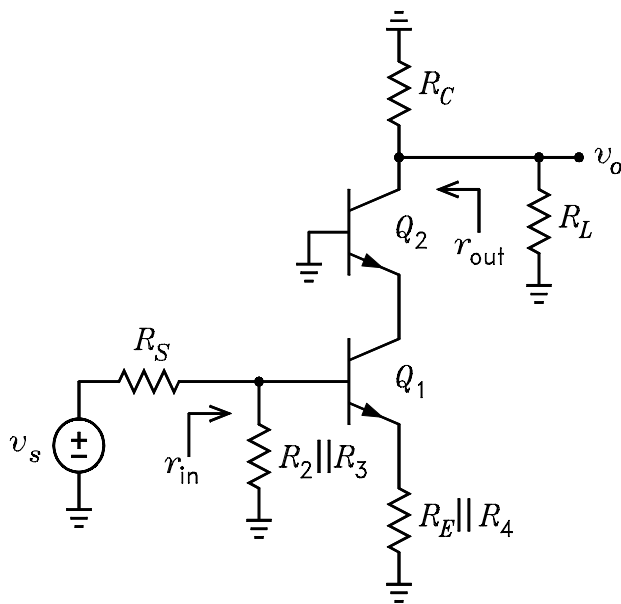

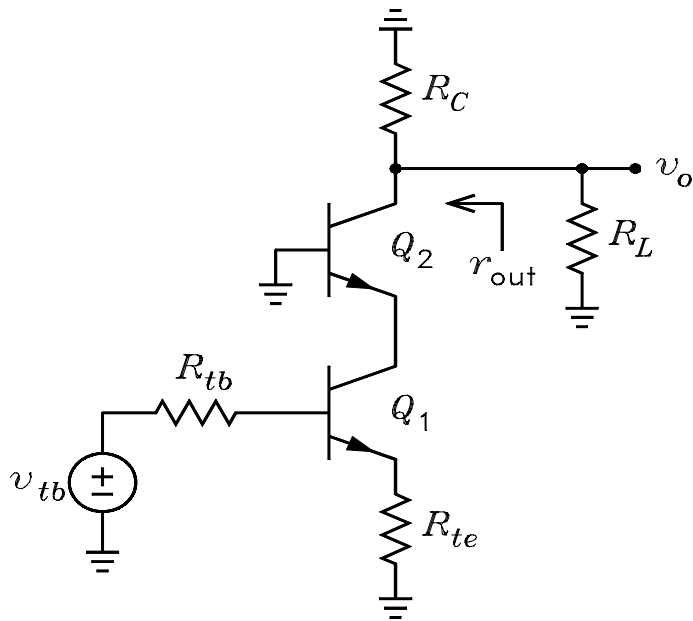

$$v_{tb1} := v_s \cdot \frac{R_p(R_2, R_3)}{R_s + R_p(R_2, R_3)}$$

$$v_{tb1} = 0.9777$$

$$R_{tb1} := R_p(R_s, R_p(R_2, R_3))$$

$$R_{tb1} = 977.6536$$

$$R_{te1} := R_p(R_E, R_4)$$

$$R_{te1} = 97.7273$$

$$r_{ie1} := \frac{R_{tb1} + r_x}{1 + \beta} + r_{e1}$$

$$r_{ie1} = 28.6805$$

$$r_{ie2} := \frac{r_x}{1 + \beta} + r_{e2}$$

$$r_{ie2} = 23.9113$$

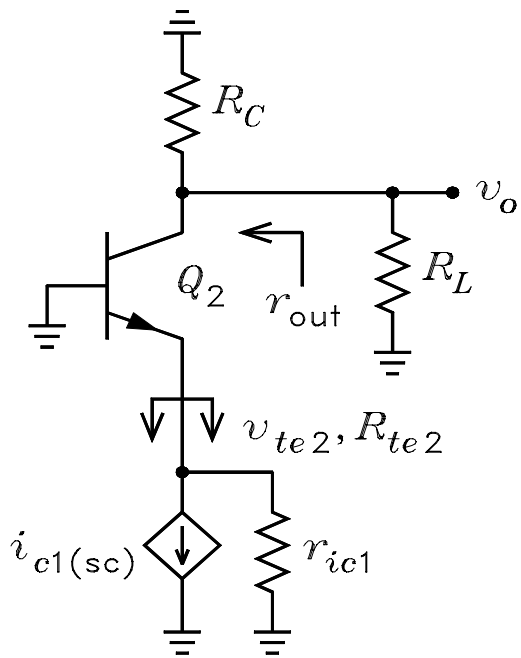

$$r_{ic1} := \frac{r_0 + R_P(r_{ie1}, R_{te1})}{1 - \frac{\alpha \cdot R_{te1}}{r_{ie1} + R_{te1}}} \quad r_{ic1} = 2.1678 \cdot 10^5$$

$$i_{c1sc} := \frac{v_{tb1}}{r_{ie1} + R_P(R_{te1}, r_0)} \cdot \left(\alpha - \frac{R_{te1}}{R_{te1} + r_0} \right) \quad i_{c1sc} = 7.692 \cdot 10^{-3}$$

$$v_{te2} := -i_{c1sc} \cdot r_{ic1} \quad v_{te2} = -1.6674 \cdot 10^3$$

$$R_{te2} := r_{ic1} \quad R_{te2} = 2.1678 \cdot 10^5$$

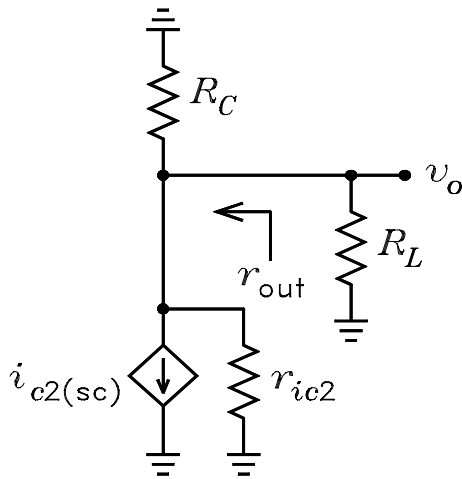

$$R_{tc2} := R_P(R_C, R_L) \quad R_{tc2} = 6.6667 \cdot 10^3$$

$$i_{c2sc} := \frac{-v_{te2}}{R_{tc2} + R_P(r_{ie2}, r_0)} \cdot \frac{\alpha \cdot r_0 + R_{tc2}}{r_0 + R_{tc2}} \quad i_{c2sc} = 7.6572 \cdot 10^{-3}$$

$$r_{ic2} := \frac{r_0 + R_P(r_{ie2}, R_{tc2})}{1 - \frac{\alpha \cdot R_{tc2}}{r_{ie2} + R_{tc2}}} \quad r_{ic2} = 9.7899 \cdot 10^6$$

$$v_o := -i_{c2sc} \cdot R_P(r_{ic2}, R_{tc2}) \quad v_o = -51.0132$$

$$A_v := v_o \quad A_v = -51.0132 \quad \text{This is the voltage gain.}$$

$$r_{out} := R_P(R_C, r_{ic2}) \quad r_{out} = 1.9959 \cdot 10^4$$

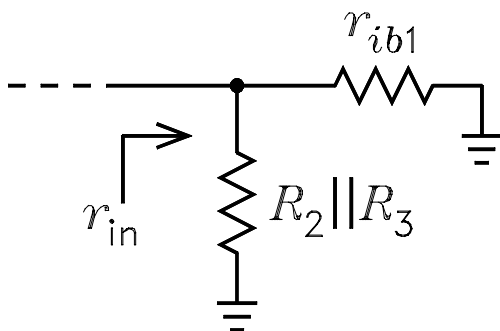

$$r_{ieo2} := r_{ie2} \cdot \frac{r_0 + R_{tc2}}{r_{ie2} + r_0 + \frac{R_{tc2}}{1 + \beta}} \quad r_{ieo2} = 27.0685$$

$$R_{tc1} := r_{ieo2} \quad R_{tc1} = 27.0685$$

$$r_{ib1} := r_x + (1 + \beta) \cdot (r_{e1} + R_p(R_{te1}, r_0 + R_{tc1})) - \frac{\beta \cdot R_{te1} \cdot R_{tc1}}{R_{tc1} + r_0 + R_{te1}}$$

$$r_{ib1} = 2.4255 \cdot 10^4$$

$$r_{in} := R_p(r_{ib1}, R_p(R_1 + R_2, R_3)) \quad r_{in} = 1.6453 \cdot 10^4$$

The following solution is based on the r_0 approximations for Q2 .

$$i_{c2sc} := \alpha \cdot i_{c1sc} \cdot \frac{r_{ic1}}{r_{ie2} + r_{ic1}} \quad i_{c2sc} = 7.6527 \cdot 10^{-3} \quad \text{The } \frac{r_{ic1}}{r_{ie2} + r_{ic1}} \text{ is a current divider.}$$

$$v_o := -i_{c2sc} \cdot R_p(R_{tc2}, r_{ic2}) \quad v_o = -50.983$$

$$A_v := v_o \quad A_v = -50.983 \quad \text{This is the voltage gain.}$$

$$r_{out} := R_p(r_{ic2}, R_C) \quad r_{out} = 1.9959 \cdot 10^4$$

$$r_{ib1} := r_x + (1 + \beta) \cdot (r_{e1} + R_{te1}) \quad r_{ib1} = 2.4304 \cdot 10^4$$

$$r_{in} := R_p(r_{ib1}, R_p(R_3, R_2)) \quad r_{in} = 1.5624 \cdot 10^4$$